

# Julian Leland

Engineering and Design Portfolio  
Fall 2014

# About Me

My name is Julian Leland. I'm a mechanical engineer at Barrett Technology, a robotics company located in Newton, Massachusetts. I graduated from Swarthmore College in 2012 with a major in Engineering (mechanical concentration) and a minor in Public Policy.

I am fascinated by the concept of *bringing tools to people* – exploring new ways of designing and creating, while seeking to make those tools and techniques available to the widest possible audience. In my coursework and work in industry, I've explored this concept through precision engineering and mechanical design. Through this, I've also become proficient with the “hammers and nails” of the engineering design process; I am a capable machinist, woodworker, CAD drafter, and electrician.

I've also pursued design from a less engineering-centric perspective – designing primarily for aesthetics rather than efficiency. I've worked on projects ranging from theater and housing construction to furniture and jewelry design, and have gained experience with a skill set that most engineers are never exposed to.

The following pages showcase a small sample of my work over the past few years, including both engineering- and design-focused projects. More information on these projects and further examples of my work are available at [julianleland.io](http://julianleland.io).

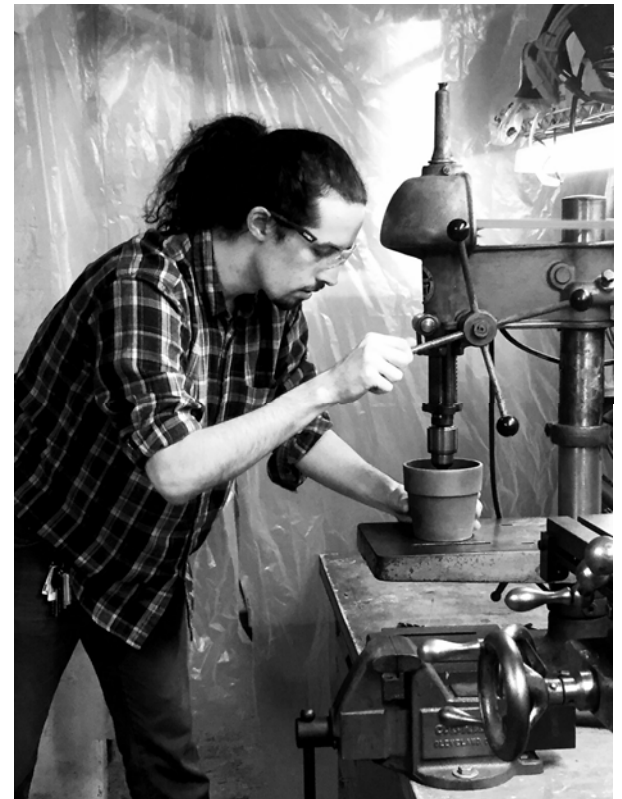

# Engineering

The following projects have been pursued through both my engineering coursework and professional work. They demonstrate my technical skill as a mechanical engineer, as well as my competence with many different fabrication techniques.

# Barrett Technology



Since Fall 2013, I have been employed as a mechanical engineer at Barrett Technology. Barrett builds and sells the cable-driven WAM arm and BarrettHand manipulator, both of which are used heavily in robotics research and light industry, and has recently released the Proficio rehabilitation therapy robot. At Barrett, I am responsible for a range of projects, from mechanical design, to manufacturing support, to advertising development. While I can't share much of my work, the following pages showcase some of my contributions, along with insights into my design process.

# Proficio Rehabilitation System



I have been an integral part of the design team developing the new Proficio robotic arm system since my arrival at Barrett. Among many others, my responsibilities have included high-level conceptual and aesthetic development; detailed subsystem- and component-level design and research; DFM analysis and optimization; assembly and testing of early systems; and IP development and protection.

# Proficio Rehabilitation System

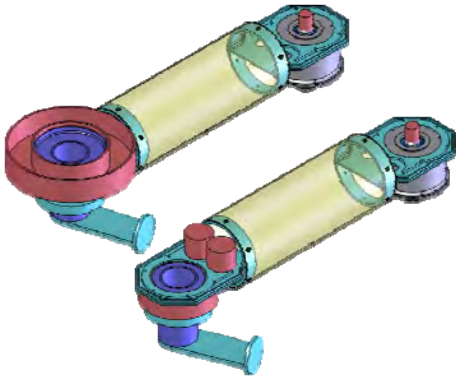
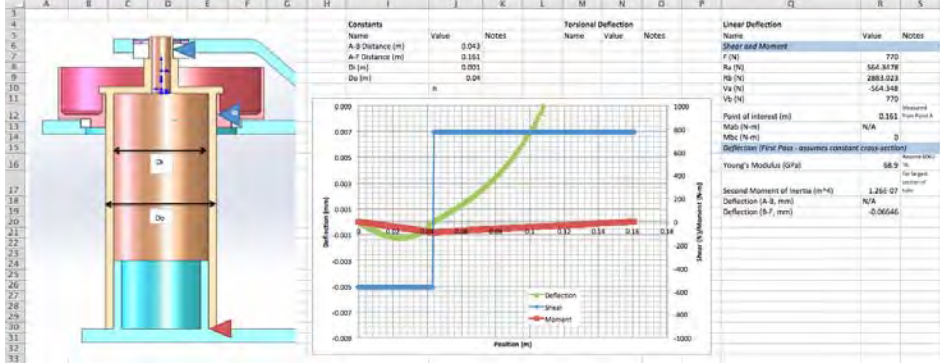
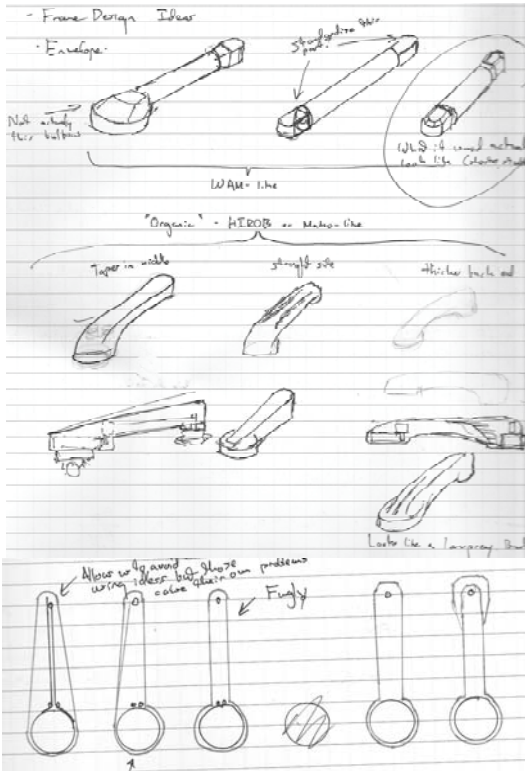

I was responsible for the high-level design of the Proficio's inner link and third joint. I considered a number of factors in my design study, including the aesthetics of the link, loads that the link's components would be required to withstand, and the design of the link's cable transmission. The images above show the progression of the link's design, from aesthetic concepts, to CAD mockups, to final product.

# Proficio Rehabilitation System

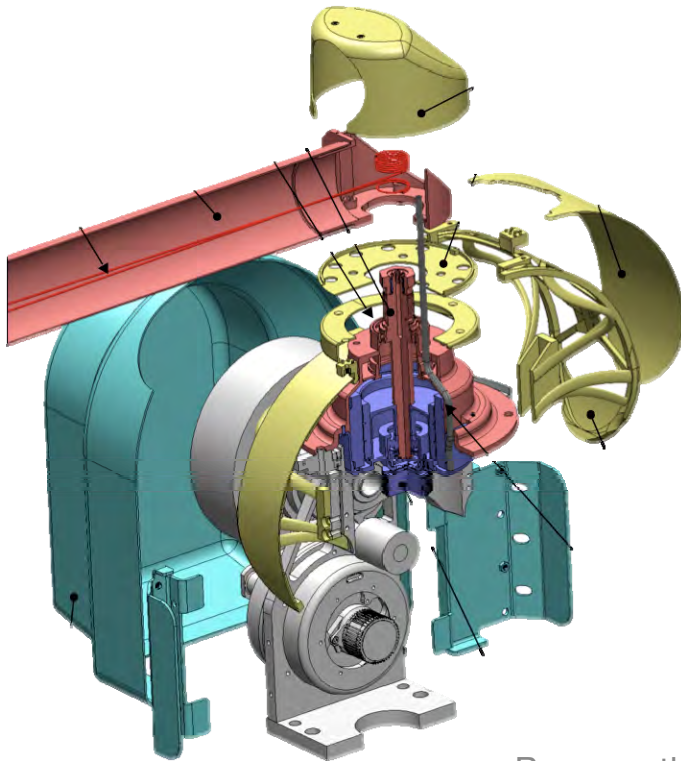

Because the Proficio is intended for in-clinic use, it must comply with robotic and medical device safety standards, including ingress and pinch protection. I was responsible for designing the cover systems that shield the internal drive components in the differential and the elbow, along with developing manufacturing processes and tooling for many of the prototype components.

# Perception Palm Sensor Suite

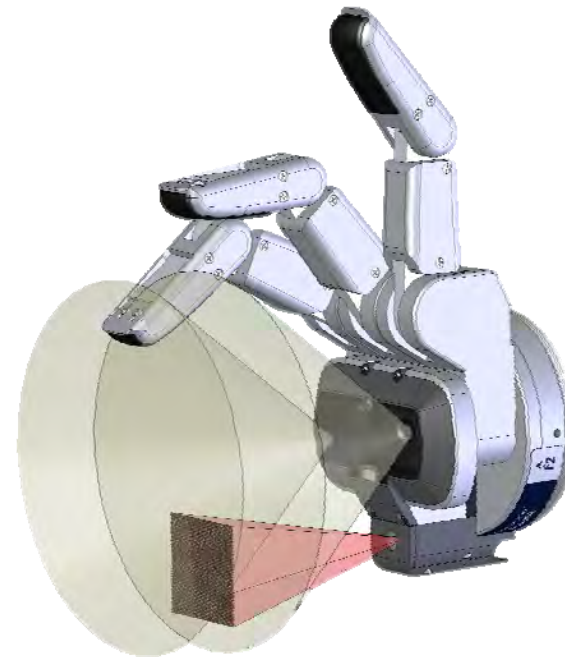

I am lead mechanical designer for the Barrett Perception Palm sensor suite for the BH8-series BarrettHand Manipulator. My responsibilities have included researching and sourcing components for the various sensor systems; developing a low-cost housing that retrofits to existing Barrett parts; developing a product BOM and manufacturing procedures; and directing a team of interns in integrating the system with the Barrett WAM arm.



# Self-Replicating Milling Machine

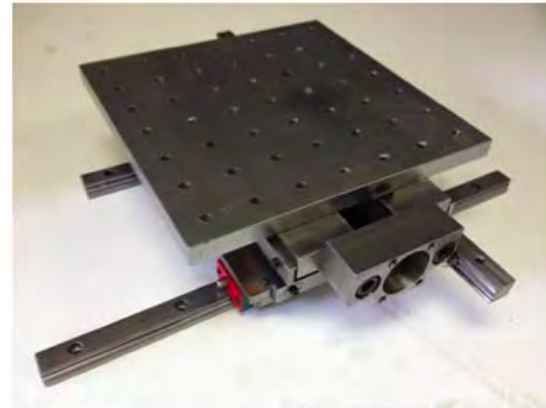
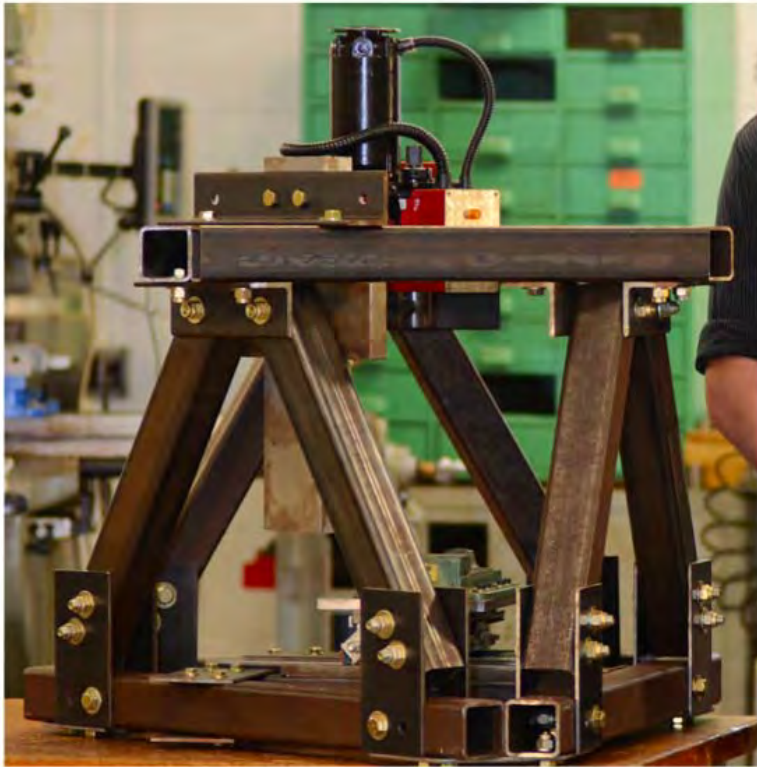

During the fall and spring of 2012, I completed my senior design project, which focused on the design and fabrication of a “self-replicating” milling machine. The idea of “self-replication” – a machine being able to make all non-standard parts involved in its manufacture – has become a buzzword in the hobbyist and maker communities with the rapid ascendancy of the RepRap 3D printer: my project focused on implementing this concept in a cost-competitive subtractive-machining formfactor. This project was generously supported by grants from ASME and IEEE-USA: my work was published by IEEE, and was featured by HackADay, MAKE: and microManufacturing Magazine.



# Suspended-Particulate Flowmeter

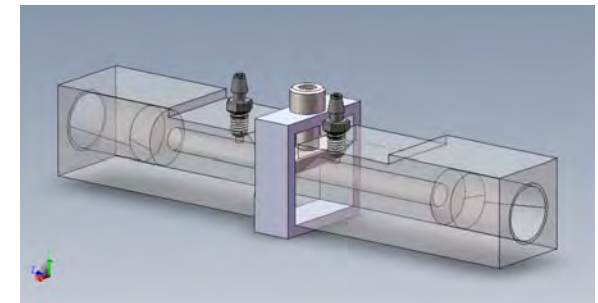
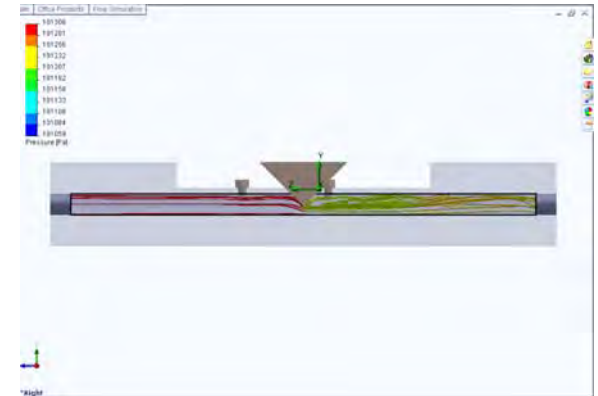

As part of my Fluid Mechanics course, I designed and built a wedge-type flowmeter to measure the flow rate of smoke through my Engineer's Hookah, below. After completing the on-paper design of the meter, I modeled and simulated fluid flow through the meter to check my calculations. I then fabricated the meter, developed an Arduino-based sensor apparatus to read the differential pressure produced by the meter, and built a housing for the electronics.

# Suspended-Particulate Flowmeter

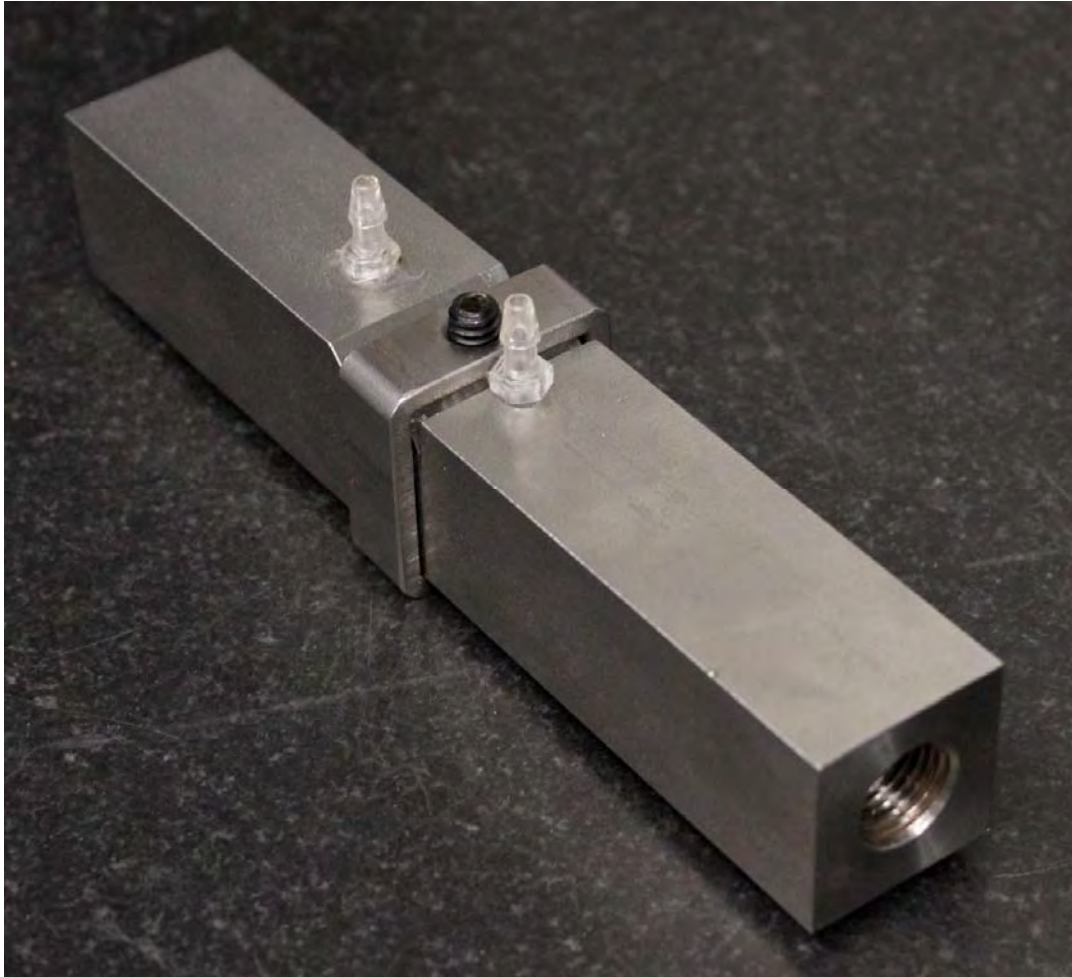

# dJay Turntable Controller

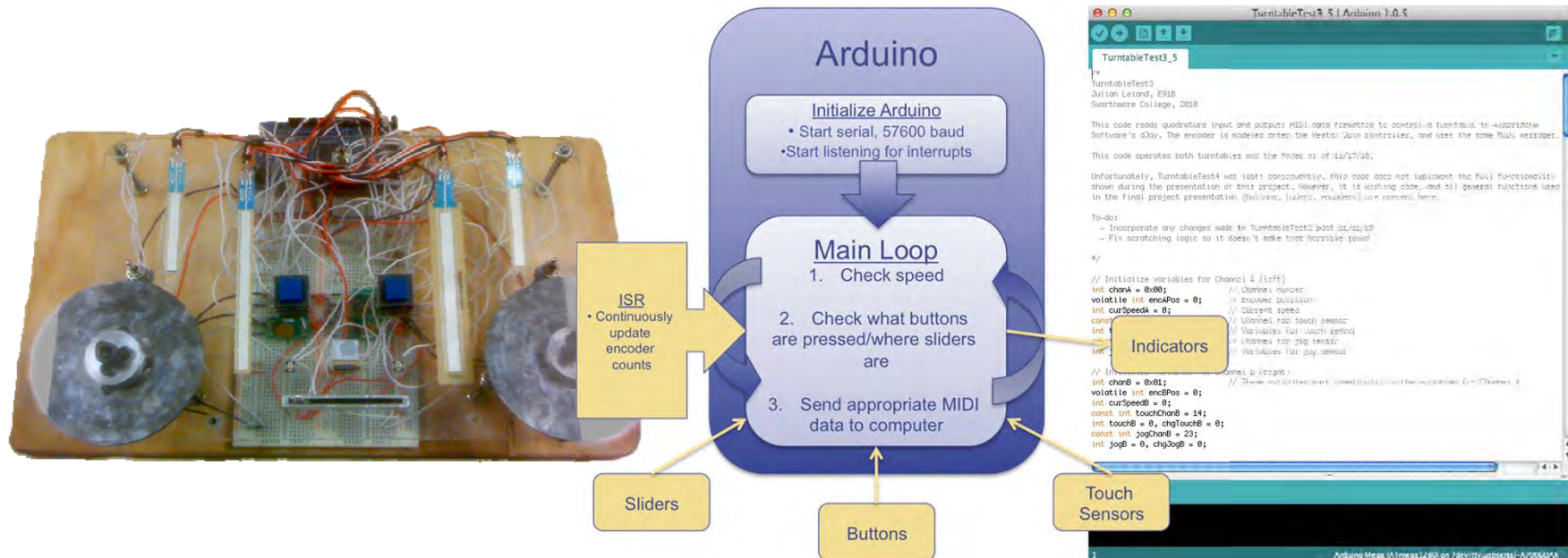

I developed a MIDI-based controller for the popular DJ application dJay as the final project for my Embedded Systems course. This project gave me an opportunity to become familiar interfacing with the many different sensors needed to simulate the wide range of input methods in the program, including touch potentiometers, capacitive sensors, powered sliders and high-resolution quadrature encoders.

# Design

In my spare time, I've been able to pursue a number of design projects where the focus is primarily on the aesthetics of the piece. Balancing visual considerations alongside manufacturability, functionality and cost-efficiency is an interesting exercise for me; as an engineer, it's important to remember that simply making something work isn't necessarily the whole solution to the problem.

# Engineer's Hookah

After being certified to work in the Swarthmore machine shops, I began designing and constructing a hookah pipe. Many commercially available hookahs are poorly constructed from low-quality materials, and most are gaudy, to say the least. In designing my hookah, I tried to create a simple, durable pipe, using materials that are heat- and food-safe – an engineer's hookah.



# Engineer's Hookah





# Pallet Construction



In 2011, I designed and built a side table for my girlfriend's apartment. The table was loosely based on the Maker Table developed by MAKE: magazine, but used hardwood from shipping pallets for the table surfaces and recovered cast-iron pipe fixtures for the frame, giving it a unique rustic-industrial look.



# Pallet Construction



# Pallet Construction



I've subsequently explored the ideas of heirloom furniture and rustic-industrial aesthetic further through a second pallet table that I built, along with a set of coasters to match. The coasters are made of reclaimed pallet knots, with tin cast into the openings; they are inspired by Hilla Shamia's work casting aluminum around hardwood.

